

# STUD WELDING PRODUCTS, INC

*your number one stud*

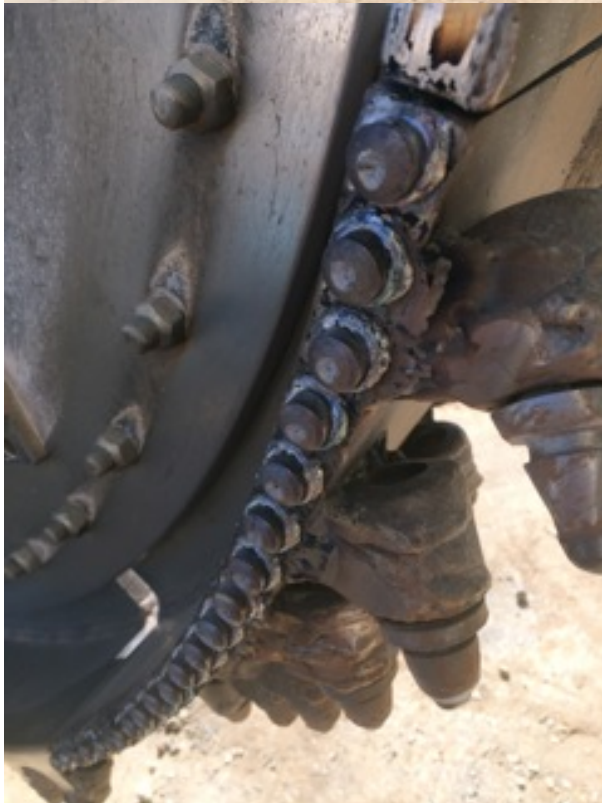

We installed a total of 88 HCA58's to the outer edges of 2 sections on a rock saw. The 2 segments have TUFFSTUDDS applied to both sides and are positioned opposite each other on the wheel (12 and 6 o'clock respectively). This component is normally protected with hard facing and will require 12 hours to complete the job. The nature of the way the studs are installed for purposes of balance, the TUFFSTUDDS will provide a significant amount of protection for any hard facing applied between sections of TUFFSTUDDS.



# STUD WELDING PRODUCTS, INC

*your number one stud*



## CAT 7495 Shovel Bucket Door

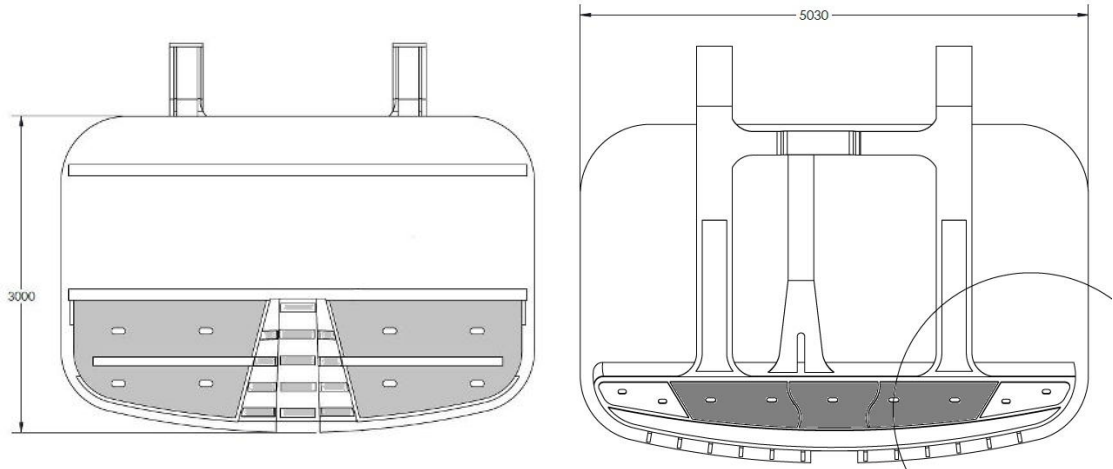

TUFFSTUDDS coverage:

Internal side of the Bucket Door: 4 m<sup>2</sup> with TSA-68

External side of the Bucket Door: 2.4 m<sup>2</sup> with TSA-78

Protection weight reduction from **1600 to 210 kg.**

